

Memory controllers

Manual and automated format alignment

Display LCD two lines, interface RS485

N 242



N 242 - Automated/manual format alignment

Features

- Memory controller for manual and automatic format alignment
- Display: LCD backlit, two lines alphanumeric, multilingual
- Programming and memory unit
- Memory for 100 formats with max. 32 position displays
- Interface RS485

Technical data - electrical ratings

Voltage supply	85...265 VAC (50/60 Hz)
Power consumption	42 VA
Reverse polarity protection	No
Sensor supply	24 VDC $\pm 10\%$ / < 0.9 A
Display	LCD-TFT, 2-lines, backlit, alphanumeric
Function	User menu, multilingual Motive positioning Memory unit for 100 format profiles Programming of max. 32 SPA SPA zero point alignment Start position for target display N 155
Keylock	Secured by code
Control inputs	Shaft release Start positioning
control outputs relay	Shafts in position Start positioning
Switching capacity relay	100 VA / 30 W
Switching current relay	1 A
Switching voltage relay	265 VAC
Interface	RS485 (ASCII protocol)
Data memory	>10 years in EEPROM
Programmable parameters	Language selection
Standard DIN EN 61010-1	Protection class II Overvoltage category II Pollution degree 2
Emitted interference	DIN EN 61000-6-4
Interference immunity	DIN EN 61000-6-2
Approval	UL approval / E63076

Technical data - mechanical design

Operating temperature	-10...+50 °C
Storage temperature	-20...+70 °C
Relative humidity	80 % non-condensing
Protection DIN EN 60529	IP 65 (face with seal)
Connection	Screw terminal connector
Core cross-section	1.5 mm ²
Operation / keypad	10 figure keypad with 8 function keys
Housing type	Built-in housing
Dimensions	144 x 144 x 116.5 mm
Cutout dimensions	125 x 125 mm
Mounting depth	120 mm
Mounting	Front panel installation by clip frame
Weight approx.	600 g
Material	Polycarbonate black, UL 94V-0

Memory controllers

Manual and automated format alignment

Display LCD two lines, interface RS485

N 242

Part number

N 242. 1 1 2 AX01

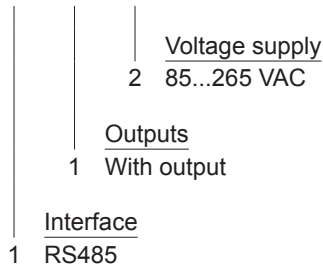

Description

N 242 memory controller intended for front panel installation serves as memory and operating unit. By RS485 network up to 100 format profiles with several position values for maximum 32 spindles can be saved and recalled for retransmission to the SPAs (spindle position displays) respectively actuators (multiconDrive) upon pressing a button. The two-line SPA display indicates both actual value and target. Similar to the SPA display, the controller is giving information whether the spindles are "in position" or "not in position".

The keypad provides 10 figures and 8 function keys allowing easy parameter input and recall. multiconDrive provides an external start key for centralized release of positioning cycles. Programmable parameters enable perfect adaptation to the application.

Programmable parameters and functions:

- tolerance window, end position switch-off
- collective groups of 5 spindles each
- teach-in of target values
- spindle pitch and compensation
- measuring unit mm/inch
- multilingual

Connection diagram

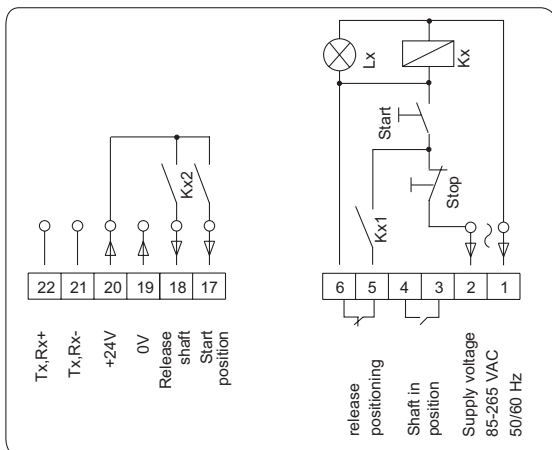

Dimensions

